

G. H. SQUIER.  
VISE.

No. 436,641.

Patented Sept. 16, 1890.

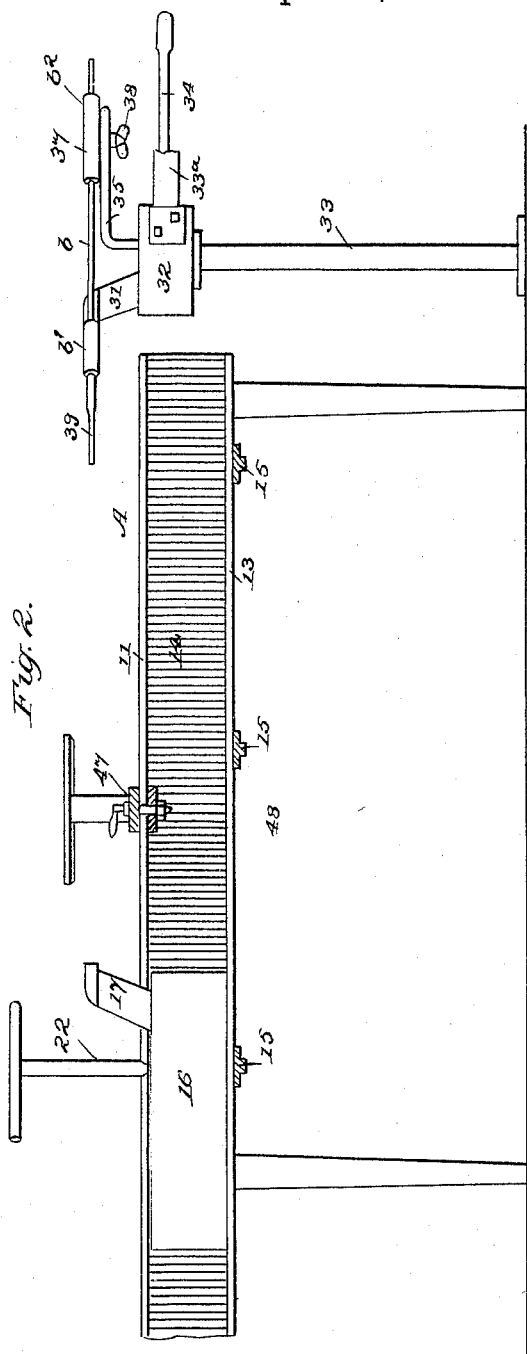
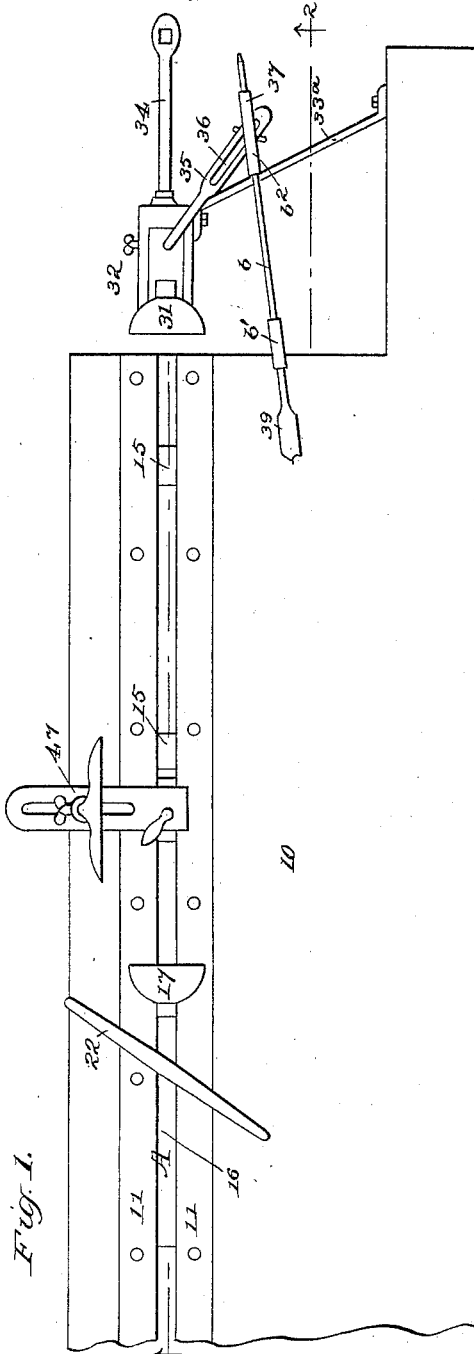

Fig. 1.

Fig. 2.

WITNESSES:

*H. C. Guinewell*  
*C. Sedgwick*

INVENTOR:

*S. H. Squier*  
*Munn & Co.*

BY

ATTORNEYS.

# G. H. SQUIER. VISE.

No. 436,641.

Patented Sept. 16, 1890.

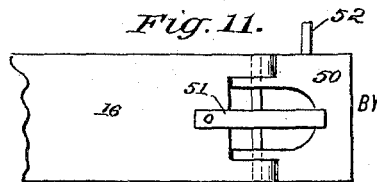
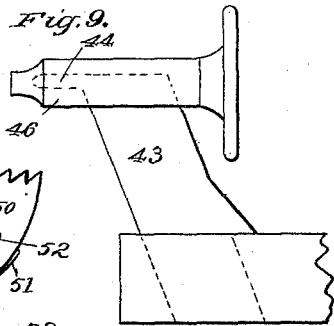
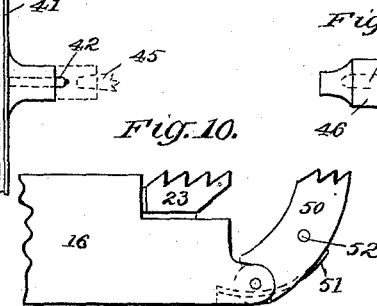
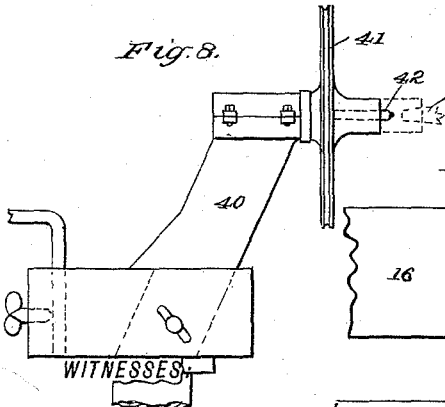
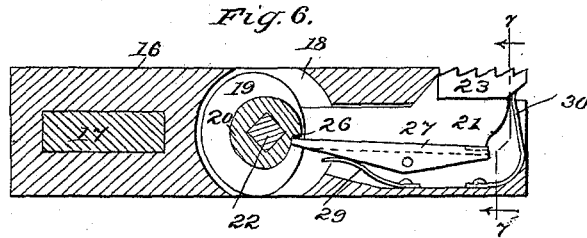
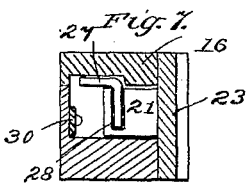
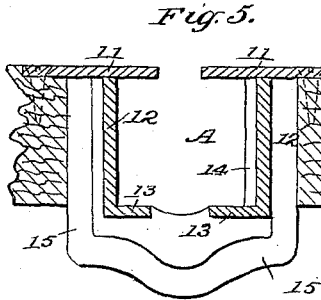
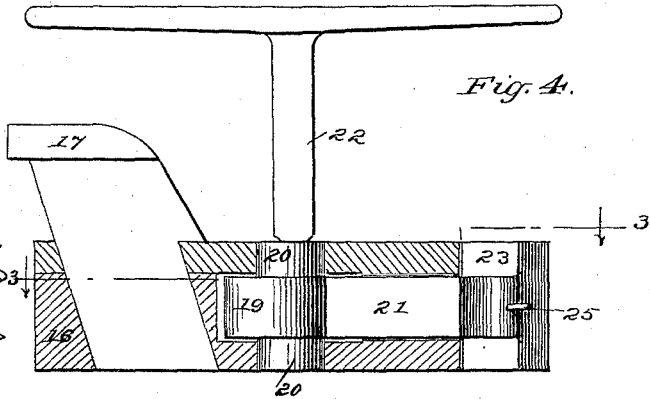
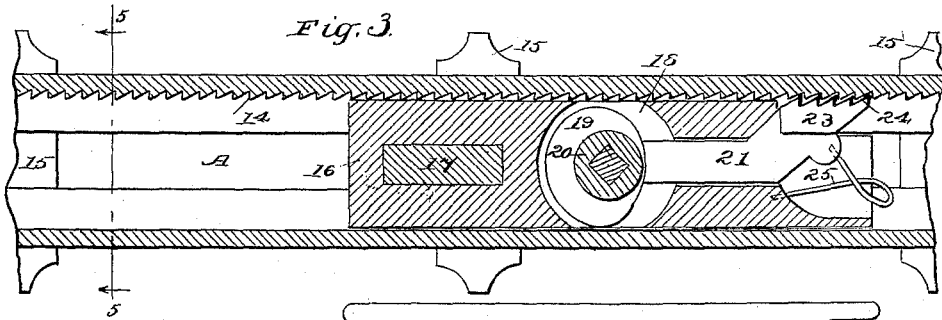

WITNESSES:  
*J. H. Griswell*  
*C. Sedgwick*

INVENTOR:  
*G. H. Squier*  
 BY  
*Munn & Co.*  
 ATTORNEYS.

# UNITED STATES PATENT OFFICE.

GEORGE H. SQUIER, OF TREMPEALEAU, WISCONSIN.

## WISE.

SPECIFICATION forming part of Letters Patent No. 436,641, dated September 16, 1890.

Application filed October 31, 1889. Serial No. 328,799. (No model.)

*To all whom it may concern:*

Be it known that I, GEORGE H. SQUIER, of Trempealeau, in the county of Trempealeau and State of Wisconsin, have invented a new and useful Improvement in Vises, of which the following is a full, clear, and exact description.

My invention relates to an improvement in vises, and has for its object to provide a device whose jaws shall have a very wide opening, and wherein this opening may at will be indefinitely increased, and also to provide for a much greater swing than heretofore, it being understood that it is not necessary that the vertical swing should be equally great throughout the entire extent of the opening of the jaws, since bodies of large superficies, for which such a vise is required, are comparatively thin.

A further object of the invention is to provide a device which, by reason of interchangeable jaws, shall be adapted to as large a range of work as possible, and especially one which may be quickly and easily transformed into an efficient lathe.

My invention consists in the novel construction and combination of the several parts, as will be hereinafter fully set forth, and pointed out in the claims.

Reference is to be had to the accompanying drawings, forming a part of this specification, in which similar letters and figures of reference indicate corresponding parts in all the views.

Figure 1 is a plan view of the device. Fig. 2 is a central vertical section on line 2 2 of Fig. 1. Fig. 3 is a horizontal section on line 3 3 of Fig. 4. Fig. 4 is a vertical longitudinal section through the sliding carrier or head. Fig. 5 is a transverse vertical section on line 5 5 of Fig. 3. Fig. 6 is a horizontal section through a modified form of sliding carrier or head. Fig. 7 is a transverse section on line 7 7 of Fig. 6. Figs. 8 and 9 are side elevations of attachments utilized to convert the vise into a lathe. Fig. 10 is a partial plan view of a modified form of the sliding carrier or head; and Fig. 11 is a side view of the same.

In a bench 10 a suitable longitudinal channel is cut of any desired length, preferably extending from end to end, in which channel

a slideway A is formed, usually constructed in two opposed parallel sections, each section consisting of a head-piece 11, adapted to be sunk in the upper face of the bench flush therewith, a perpendicular body portion 12, and an inwardly-extending horizontal lower or base portion 13, the head 11 being so constructed as to extend horizontally beyond both sides of the body-section 12, as best shown in Fig. 5.

Upon the inner face of the body-section 12 of one of the sections of the slideway a series of vertical teeth 14 are produced, and usually in the construction of the device the slideway is braced at suitable intervals in its length by means of yokes 15.

The carrier or head 16, adapted to travel in the slideway A, consists of a casting or castings of any suitable construction fitted externally to move freely in the said slideway. The carrier or head is ordinarily constructed rectangular in general contour, and is provided near its forward end with a socket, in which one clamping-jaw 17 of the vise is inserted. This carrier or head is also provided with a longitudinal, essentially central, channel 18, of varied diameter, extending from a point at or near the center to the rear end. Within the forward end of the channel 18, which is at this point usually circular, a cam 19 is located and held to turn freely therein by reason of the trunnions 20 of the cam being journaled in opposite sides of the carrier or head, as best shown in Fig. 4, the cam being so constructed that its middle zone rises gradually, so as to form inclined planes adapted to bear against the end of a dog 21, held to slide in the outer portion of the channel 18. It will thus be observed that by this formation the cam 19 partakes of the nature of an eccentric. A rectangular recess or bore is produced vertically in the cam and its trunnions, adapted to receive the lower squared end of a key 22, which key is preferably shaped somewhat in the form of a T, as illustrated in Fig. 4, the office of the key being to revolve the cam 19 when the carrier or head is to be given a forward movement. The key 22 may be readily detached from its seat in the cam when not required for use.

The outer end of the dog 21 is carried in the direction of the teeth 14 of the slideway,

as best shown in Fig. 3, and upon the outer side face of this angular section of the dog a contact-face 23 is formed, which face is of a height equal to the length of the teeth 14 and provided with teeth 24, adapted to mesh or contact with the slideway-teeth 14. A spring 25 is attached to the dog and to the carrier or head, which spring usually consists of a piece of suitable wire having one end secured to the carrier or head and the other end to the inner side of the dog immediately at the rear of its contact-face, the central portion of the spring being in loop form, as best shown in Fig. 3. The forwardly-projecting member of the spring 25 is so inclined to the horizontal member that when the dog is pressed backward by the rotation of the cam 19 a downward pressure is exerted upon the horizontal member, and when the dog is released from the cam the spring acts to restore the former to its normal position.

In the operation of the carrier or head it is obvious that as the eccentric surface of the cam is brought to bear upon the inner end of the dog 21 the contact-face 23 of said dog will be made to mesh with the teeth 14 of the slideway, and as the said eccentric surface of the cam is continued in contact with the dog the dog acts as a lever to push the carrier or head forward, since the cam is attached directly to the carrier or head. When the concentric face of the cam approaches the dog, the spring 25 commences to act and forces the said dog to its normal position, whereupon at the next revolution of the cam the carrier or head is again propelled forward in a similar manner to that above described.

In Fig. 6 I have illustrated a slightly-modified form of the interior mechanism of the carrier or head, which has the advantage of holding the dog against the rack of the slideway in such manner as to prevent all possibility of its slipping. The cam 19 remains the same; but one trunnion 20 is provided with an abrupt shoulder 26, adapted for contact with the inner end of a centrally-fulcrumed lever 27, which lever is located immediately above the dog 21, and the rear end of said lever is bent downward and introduced into a channel 28, formed in the outer end of the dog, as best shown in Fig. 7, whereby as the cam is revolved, when the shoulder 26 of the trunnion contacts with the inner end of the lever 27, the said inner end is carried in one direction against the tension of a spring 29, and the outer end, attached to the dog, is carried in the opposite direction, and the contact-face of said dog is thereby forced to an engagement with the rack 14. This action takes place just as the eccentric surface of the cam commences to act upon the inner end of the dog. The spring 29 normally retains the lever 27 in a position essentially parallel with the longitudinal axis of the carrier or head, and a second spring 30, located at the rear end of the carrier or head within the channel 18, has a bearing at its upper end

against the rear end of the contact-face of the dog, which spring 30 has a tendency at all times to force the dog inward and keep it in contact with the cam. Thus it will be observed that the jaw 17 may be fed forward, as occasion may demand, to approach a fixed jaw, hereinafter described. The carrier or head is readily slipped backward to increase the distance between the sliding jaw and a fixed jaw when the dog 21 is out of contact with the rack or in the position illustrated in Fig. 3.

The fixed jaw 31 is introduced into a socket formed in a head or block 32, which block is supported in any suitable or approved manner at one end of the table 10 in such a way that the fixed jaw will be immediately opposite the sliding jaw 17. This is usually effected by mounting the block 32 upon a pedestal 33, attached to the floor or to any other support upon which the bench rests, a brace 33<sup>a</sup> extending from the block to the table, or other equivalent mechanism may be substituted for the brace. This head or block 32 carrying the fixed jaw is entirely independent of the table 10 and the slideway, and no connection whatever is made between this fixed jaw and the sliding jaw.

If in practice it is found desirable, the block 32 of the stationary jaw 31 may be fed forward in any approved manner, a screw 34 being illustrated in the drawings to accomplish that end.

From the head or block 32 an angled bracket 35 is projected, the horizontal member whereof at its outer end is provided with a longitudinal slot 36, and in said slot an arm 37 is held to slide, being regulated by a suitable set-screw 38 and adapted to hold in proper position an auger-bit or other equivalent tool 39, supporting the same in a horizontal position over the table 10.

It will be understood that the fixed jaw may be attached to either end of the bench, and by a corresponding arrangement of the parts the device may be rendered, respectively, either a right or a left hand vise.

A feature of the invention consists in making the jaws removable and interchangeable, by which arrangement not only can jaws of the usual form be employed, but other and special forms of every possible description may be also used, requiring but a few seconds to substitute one for the other, since each jaw is introduced into a socket or its equivalent produced in that portion of the device adapted to carry the jaws.

From the foregoing description it will be observed that by producing a table or bench with the slideway described, and also by reason of the wide opening obtained between the jaws 17 and 31, it presents, essentially, the features of a lathe-bed, and that the sockets holding the jaws may be made also to hold standards for carrying the working portions of a lathe.

In Figs. 8 and 9 I have illustrated such

standards, the one 40 (shown in Fig. 8) being adapted to carry a pulley 41, which may revolve on a pin 42. When so constructed, the opposite standard 43 is provided with a similar projecting and aligning pin 44, as shown in dotted lines. This form of standards is especially adapted for wood-turning.

Instead of the above construction the standard 40 may be more perfectly formed, the pulley being made to revolve in bearings upon the top of the standard and having its outer end fitted to receive any of the usual forms of chucks, as illustrated at 45. In the latter event the opposite center 46 may be of the ordinary construction.

The standards 40 and 43, and likewise the standards or shanks having the jaws 17 and 31 attached, are preferably given a gradual inclination in the direction of each other.

The lathe-rest 47 is of the usual construction, and is only introduced to show the manner of its adjustment, which is by means of a block 48 passed beneath the slideways.

The auger-carrying arm heretofore referred to usually consists of the following parts: a shaft *b*, formed of a round rod of steel or other metal having at one end any of the usual forms of auger-holding devices *b'*, the other end being square to fit into a common bit. The shaft is held to revolve in a sleeve *b<sup>2</sup>*, secured at its center by the set-screw 38 to the slotted arm of the bracket 35, as heretofore set forth. Thus the sleeve and the shaft it carries are capable of receiving angular movement in a horizontal plane.

In Figs. 10 and 11 I have shown a second modification of the carrier or head in which the supplemental pawl 50 is hinged at the end carrying the dog 53. This supplemental pawl is held in position to contact with the rack 14 by a spring 51, and is provided with a pin 52, capable of extending upward through the slideway A. By reason of the additional pawl 50 a continuously-progressive forward movement may be imparted to the carrier or head. By pushing the pin 52 to one side the pawl 50 may be disconnected from the rack when desired. The addition of the pawl 50 is very desirable when a yielding or elastic body is to be compressed more than it is possible to accomplish with one turn of the cam, as without the pawl the expansion of the body would force the carrier or head backward and release the dog from the rack.

I desire it to be distinctly understood that the form of the cam 20 may be changed, and that, though specific construction of details has been shown and described, I do not confine myself thereto, as other equivalent construction may be employed without departing from the spirit of the invention.

Having thus described my invention, I claim as new and desire to secure by Letters Patent—

1. The combination, with a guideway, of a sliding head or carrier, a dog having independent longitudinal movement on the head

or carrier, movable bodily therewith, and projecting at its outer end laterally beyond one side of the carrier into engagement with one wall or face of the guideway, and an actuating device carried by the sliding head and engaging the inner end of the dog, whereby the force exerted on the dog will cause the sliding head to be moved forwardly along the sliding way, substantially as set forth.

2. The combination, with the guideway having a rack, of a head or carrier movable longitudinally along the guideway, a dog having independent longitudinal movement on the carrier movable bodily therewith, and projected laterally at its outer end into engagement with the guideway-rack, and a cam mounted on the sliding head or carrier and bearing on the inner end of the dog, said cam being constructed to be operated from the exterior of the guideway, substantially as set forth.

3. The combination, with the carrier or head having a longitudinally-extending opening, of a dog movable longitudinally in said opening, projecting at its outer end laterally beyond one side of the carrier, a cam mounted on the carrier or head at the inner end of said dog, and a spring secured to the carrier or head and engaging the opposite end of the dog, substantially as set forth.

4. The combination, with the carrier or head having a longitudinally-extending opening, of a dog movable lengthwise in said opening and projecting at its outer end laterally beyond one side of the carrier, a spring secured to the carrier and bearing against the outer end of said dog, a lever pivoted between its ends in said longitudinally-extending opening and bearing on the rear side of the outer end of the dog, and a cam bearing on the inner end of the dog and having trunnions journaled in the carrier or head, one trunnion having a shoulder to engage the inner end of said lever, substantially as set forth.

5. The combination, with the sliding head or carrier provided near its forward end with a shank-receiving socket and in advance thereof with a longitudinally-extending bore or opening, of a cam journaled at the inner end of said bore or opening, a dog extending longitudinally along said opening, resting at its inner end against the cam, and projecting laterally beyond one face of the head, and a spring secured to the head and engaging the outer end of the dog, substantially as set forth.

6. The combination, with the longitudinally-extending guideway and a sliding head or carrier adjustable thereon, of a stationary head or block adjacent to the inner end of said guideway and a support for said head or block wholly independent of and separate from said guideway, substantially as set forth.

7. The combination, with the guideway open at its upper side and having a longitudinally-extending rack, of the sliding head within the guideway, provided with an operating cam

and dog, the cam having a key-socket accessible through the open upper side of the said guideway, substantially as set forth.

8. An apparatus of the character described, consisting in the bench having a longitudinally-extending channel, the slideway therein, constructed of two opposed parallel sections, each consisting of a head-piece 11, perpendicular body portion 12, base portion 13, and vertical teeth 14 on the inner face of one portion 12, the sliding head within said slideway and provided with a longitudinally-extending opening, a dog movable endwise in said opening and projected laterally at its rear end into engagement with teeth 14, a cam journaled in the said sliding head or carrier at the inner end of the said dog and provided with a key-socket accessible through the slideway, and a post 33, adjacent to the inner end of the bench and provided at its upper end with an

opposing head or block 32, said movable and stationary heads having shank-sockets, substantially as set forth.

9. In an apparatus of the character described, the stationary head or block 32, having a central socket and a support, the slotted bracket 35, projecting centrally from the top of said head, the adjustable sleeve  $b^2$ , set-screw 38, securing said sleeve to the slotted arm, and a shaft  $b$ , journaled in said sleeve and having a tool-holder at its forward end, the slideway in longitudinal alignment with the head or block 32, and the sliding head within the slideway provided with a socket, substantially as set forth.

GEORGE H. SQUIER.

Witnesses:

ROBT. RASMUSSON,  
H. A. TOWNE.